

20-Gb/s PDM-RZ-DPSK Transmission With 40 krad/s Endless Optical Polarization Tracking

Benjamin Koch, Reinhold Noé, *Senior Member, IEEE*, David Sandel, *Member, IEEE*, Vitali Mirvoda, Jan Omar, and Kidsanapong Puntsri

Abstract—An endless polarization tracker detects and minimizes interchannel interference, enabling automatic optical polarization demultiplex and consecutive direct detection of a 20-Gb/s polarization division multiplex RZ-DPSK signal at polarization scrambling speeds up to 40 krad/s. Transmission over 430 km of fiber is error-free.

Index Terms—Optical fiber communication, optical fiber polarization, phase shift keying.

I. INTRODUCTION

AUTOMATIC polarization demultiplex in the optical domain enables polarization division multiplex (PDM) with direct detection receivers, where power consumption and development cost are significantly lower compared to coherent receivers. Also, in non-birefringent X-cut, Z-propagation LiNbO₃ crystals with PMD well below 100 fs the bandwidth of optical polarization control is roughly 2 orders of magnitude higher than that of electronic polarization controllers.

An endless polarization controller [1] transforms the variable input polarization of a channel into a fixed eigenstate of a polarization beam splitter. The outputs of the splitter deliver the two separated polarization channel signals. Feedback for the controller is provided by detecting interchannel interference.

Many publications demonstrate the usability of this approach, at high bit rates [2]–[13] and at high tracking speed [12]. Commercial demultiplexer cards [14] can easily be integrated in receiver boards. Broadband interference between the DQPSK modulations of the polarization channels can be minimized for best demultiplexing [5]. In PDM-ASK systems things are quite different: A sinusoidal differential phase modulation between the polarization channels leads to a Bessel spectrum of the mean intensity. At least one even and one odd Bessel line of the lowpass-filtered photocurrent are detected in order to get an error signal that is independent of the mean interchannel phase difference [3]. Neither scheme is applicable

Manuscript received January 2, 2013, revised February 7, 2013; accepted February 27, 2013. Date of publication March 8, 2013; date of current version April 9, 2013.

B. Koch and R. Noé are with the University of Paderborn, Paderborn 33098, Germany, and also with Novoptel GmbH, EIM-E, Paderborn 33098, Germany (e-mail: koch@ont.upb.de; noe@upb.de).

D. Sandel, V. Mirvoda, J. Omar, and K. Puntsri are with the University of Paderborn, Paderborn 33098, Germany (e-mail: sandel@ont.upb.de; mirvoda@ont.upb.de; omar@ont.upb.de; puntsri@ont.upb.de).

Color versions of one or more of the figures in this letter are available online at <http://ieeexplore.ieee.org>.

Digital Object Identifier 10.1109/LPT.2013.2251877

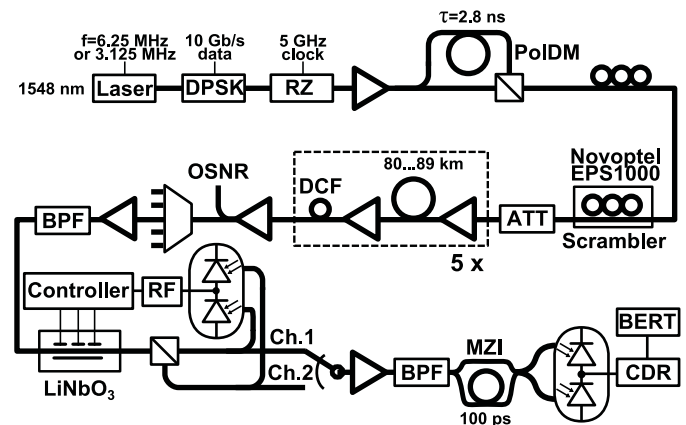

Fig. 1. Setup for 20-Gb/s PDM-RZ-DPSK transmission. An endless, electro-optic polarization controller with interference detection demultiplexes the two polarization channels, enabling consecutive direct detection.

for PDM-DPSK. PDM-DPSK has been demultiplexed in [9]; tracking speed was not specified.

In this letter, we present an interference detection approach for PDM-DPSK. It is also applicable for the related modulation format PDM-duobinary. A 20-Gb/s PDM-RZ-DPSK signal is transmitted over 430 km while tracking 40-krad/s fast, endless polarization changes.

II. PDM-DPSK TRANSMISSION SETUP

Fig. 1 shows the setup. A 1548 nm DFB laser runs as a CW source, but the pump current is sinusoidally modulated with the frequency f equal to 6.25 or 3.125 MHz. The amplitude is small so that there is an optical frequency modulation $\Delta F_{pp} \approx 137$ MHz peak-to-peak while the intensity is almost constant. This laser signal is passed through a DPSK modulator which impresses a 10 Gb/s 2^2-1 PRBS, through a CS-RZ modulator driven at 5 GHz and an EDFA. For polarization multiplex emulation, the modulated signal is split into two branches. One of the branch signals is delayed by $\tau = 2.8$ ns for proper channel decorrelation before they are superimposed bit-aligned and with orthogonal polarizations in a polarization beam splitter/combiner (PBS). The delay of $\tau = 2.8$ ns is not only used for proper channel decorrelation, but in conjunction with laser FM also to make the channel interference independent of the channel phase difference, as will be shown in Section III. This is needed to enable fast polarization tracking.

For testing purposes the transmitted polarizations are scrambled at speeds of up to 40 krad/s in an endless polarization

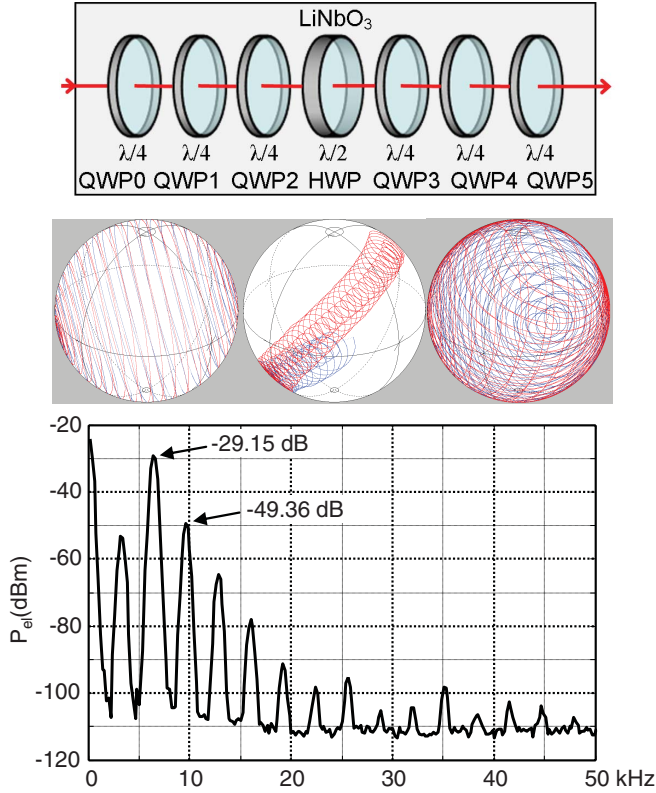

Fig. 2. Top: setup of polarization scrambler. Middle: polarization trajectories on Poincaré sphere generated by polarization scrambler, for cases of the first three QWPs (left), last three QWPs (middle), and all QWPs running (right). HWP is running in all cases. Bottom: averaged scrambling spectrum with HWP generating polarization changes of 40 krad/s peak speed.

scrambler (Novoptel EPS1000). It contains a fast rotating LiNbO₃ halfwave plate (HWP, here used up to 40 krad/s) between triples of rotating LiNbO₃ quarterwave plates (QPW, with incommensurate speeds between 6 and 14 rad/s per QWP), see Fig. 2 top. For a single-polarization signal the resulting trajectories would be circles of the polarization with varying radius on the Poincaré sphere (Fig. 2 middle; see caption). This radius is equal to $\sqrt{1 - S_3^2}$, where S_3 is the circular Stokes parameter of the input signal, which is made fairly evenly distributed by the preceding 3 QWPs. The orientations of the circles are fairly evenly distributed over the sphere by the 3 subsequent QWPs. This extremely demanding scenario comprises many reiterating continuous worst-case trajectories. Mean polarization scrambling speed is $\pi/4$ times the maximum one. Fig. 2 bottom shows the photodetected electrical spectrum of a single-polarization scrambled signal passed through a subsequent polarizer. This is displayed in average mode, over variations of the 6 QWPs. The dominating spectral line is due to the fast-running HWP; the others are at least 20 dB down.

The 20-Gb/s PDM-RZ-DPSK signal is transmitted over 5 fiber spans with 80...89 km lengths (in total 260 km of NZDSF, 170 km of SSMF, EDFAs, DCMs for 210 km of SSMF). Residual chromatic dispersion is small enough for our 10 Gbaud signal. Before transmission, the signal is attenuated and amplified again for adjustment of OSNR, measured behind the fiber spans. A 78 GHz wide DWDM DEMUX filter and

subsequent 145 GHz and 292 GHz wide optical filters remove excess noise.

In the receiver, the signal polarizations are first stabilized by an X-cut, Z-propagation LiNbO₃ polarization transformer having a PMD of about 29 fs with an FPGA-based controller. Then they are split for demultiplexing. In each PBS output, 10% of the signal power is tapped into a 10 GHz PIN-photoreceiver. The optical paths are length-matched. A Schottky detector measures the RF power of the difference of the two photoreceiver output signals. The normalized RF power is referred to as the relative intensity error (*RIE*). The controller modulates its control voltages, analyzes and minimizes the *RIE*. The default averaging time of the controller is 80 ns, which permits DQPSK operation with a tracking speed of 40 krad/s. Corresponding to one period of the transmitter modulation frequency f , the averaging time is increased to $T = 1/f = 160$ ns or 320 ns for DPSK operation.

III. DPSK INTERFERENCE DETECTION

The two polarization channel signals arrive in the PBS with angles δ_1 , δ_2 on the Poincaré sphere relative to one PBS eigenstate. Due to polarization orthogonality the separation angle between the channel signals is $\delta_1 + \delta_2 = \pi$. The interference portion of one detected photocurrent is proportional to $\cos(\delta_1/2) \cos(\delta_2/2) \cos \psi = 1/2 \cdot \sin \delta_1 \cos \psi$ where $\psi = \psi_m + \Delta \psi$ is the phase angle between the polarization channel signals. It depends on the DPSK modulation phase ψ_m but also on polarization transfer characteristics and on the phase delay of the polarization multiplexer, which are summarized under $\Delta \psi$. The interference portion of the photocurrent detected at the other PBS output has opposite sign so that the photoreceiver output signal difference is $\sim \sin \delta_1 \cos \psi$. The measured RF power is $\sim \sin^2 \delta_1 \cos^2 \psi$ where the overbar means averaging over one period $T = 1/f$.

For DQPSK modulation, ψ_m quickly changes over all 4 quadrants with equal probabilities and it holds $\overline{\cos^2 \psi} = (1/2)(1 + \cos(2\psi)) = 1/2$. The polarization controller can hence minimize $\sin^2 \delta_1$ to become zero for optimum polarization demultiplex.

DPSK signals—and duobinary signals, for which the same scheme is applicable—are modulated in only one quadrature, but other than standard ASK signals they have no carrier. The polarization channels interfere only when ψ is sufficiently close to 0 or π . The modulation phase ψ_m equals 0 or π . Hence we can set $\overline{\cos^2 \psi} = \overline{\cos^2 \Delta \psi} = (1/2)(1 + \cos(2\Delta \psi))$. As a consequence, interference must be adequately randomized, by modulating $\Delta \psi(t)$ so that $\overline{\cos(2\Delta \psi(t))} = 0$ holds.

Let us apply a momentary optical frequency excursion $F(t) = \Delta F_{pp}/2 \cdot \sin(2\pi f(t + \tau/2))$. This corresponds in both polarization channels to a momentary phase excursion $\Psi(t) = -\Delta F_{pp}/(2f) \cdot \cos(2\pi f(t + \tau/2))$. The doubled phase difference between the polarization channels is found as $2\Delta \psi(t) = 2(\Psi(t) - \Psi(t - \tau) + \langle \Delta \psi \rangle) = 2\eta \sin(2\pi f t) + 2\langle \Delta \psi \rangle$.

Here $\langle \Delta \psi \rangle$ is the static phase difference due to the mean phase delay of the polarization multiplexer and all polarization transformations, and $2\eta = 2\pi \Delta F_{pp} \tau \sin c(\pi f \tau)$ is

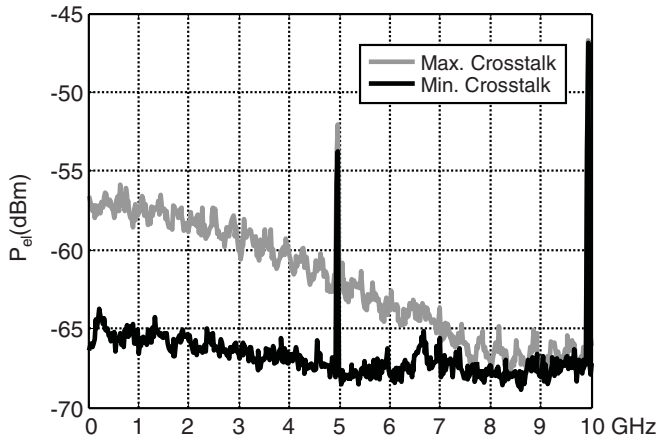

Fig. 3. RF power spectra at polarization demultiplexer output. Black: minimum channel crosstalk. Grey: maximum channel crosstalk.

the angular modulation index of $2\Delta\psi(t)$. We look at the expansion

$$\begin{aligned} & \cos(2\Delta\psi(t)) \\ &= (J_0(2\eta) + 2\sum_{k=1}^{\infty} J_{2k}(2\eta) \cos(2k2\pi ft)) \cos(2\langle\psi\rangle) - (2\sum_{k=1}^{\infty} J_{2k-1}(2\eta) \sin((2k-1)2\pi ft)) \sin(2\langle\psi\rangle) \end{aligned} \quad (1)$$

All Bessel lines of order ≥ 1 average out over T . The only condition to be fulfilled is $J_0(2\eta) = 0$. To solve this we choose $2\eta \approx 2.405$ and achieve $\cos(2\Delta\psi(t)) = 0$ with the lowest possible frequency deviation

$$\Delta F_{pp} = \frac{1.202}{\pi \tau \sin c(\pi f \tau)} \quad (2)$$

137 MHz in our setup. A $\pm 10\%$ error of η yields $|J_0(2 \cdot 1.202 \cdot (1 \pm 0.1))| \leq 0.13$, i.e., a 13% interference ripple.

IV. EXPERIMENTAL RESULTS

Total RF interference power is minimized by the polarization controller, or maximized manually when control is off. Fig. 3 shows the RF power spectra at the PBS output. Minimum (black) and maximum (grey) channel crosstalk are shown. The nonideal RZ modulation (even and odd pulses are not exactly equal) causes a peak at half the clock frequency in both cases. The RF power difference between minimum and maximum crosstalk is 6 dB.

The averaging time was set to $T = 1/f = 160$ ns. Polarization channels were selected at will by triggering automated channel swapping. In this procedure the controller is turned off, then switched to a roughly orthogonal polarization selection, and finally turned on again. Both channels and both PBS outputs showed similar performance. Laser frequency modulation, required for proper DPSK crosstalk detection, did not influence transmission.

Fig. 4 shows OSNR performance of transmitter and receiver back-to-back for different polarization scrambling speeds. The control gain of the polarization controller was adjusted to achieve maximum tracking speed. At an OSNR of 15.6 dB, BERs of $5.2 \cdot 10^{-8}$ and $1.1 \cdot 10^{-7}$ are reached at slow (0.05 krad/s) and high (40 krad/s) scrambling speed,

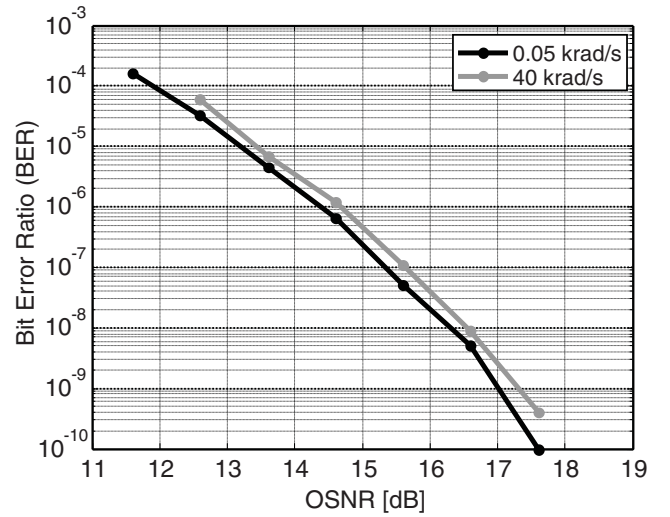

Fig. 4. OSNR performance of transmitter and receiver with slow (0.05 krad/s, black) and fast (40 krad/s, grey) polarization changes at 160 ns averaging time.

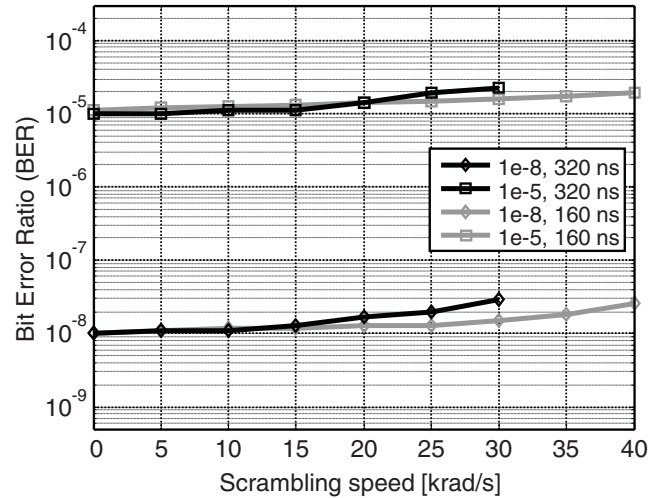

Fig. 5. Bit error ratios (BER) as function of the polarization scrambling speed, starting at BER = 10^{-8} and 10^{-5} with averaging times $T = 160$ and 320 ns.

respectively. Over the whole measured OSNR range, 40 krad/s scrambling causes OSNR penalties of ~ 0.3 dB.

Next, the influence of polarization scrambling at constant OSNR was investigated, see Fig. 5. Starting at BERs of 10^{-5} and 10^{-8} , scrambling speed was increased in 5-krad/s steps to the fastest speed that allowed reliable tracking by the controller. In systems where interference contains more noise, the averaging time could be increased, for example to $T = 320$ ns. The maximum tracking speed is then reduced to 30 krad/s. For a given scrambling speed of 30 krad/s, BER drops from $2.9 \cdot 10^{-8}$ to $1.5 \cdot 10^{-8}$ and from $2.3 \cdot 10^{-5}$ to $1.6 \cdot 10^{-5}$ at shorter averaging time.

Finally the 430 km transmission link was inserted into the setup. At maximum OSNR of ~ 20 dB, transmission was error-free. OSNR was reduced to achieve a BER of $\sim 10^{-8}$. The BER showed slow fluctuations over ~ 2 decades due to interferometer drift. Fig. 6 shows the BER plot over > 3.75 hours in intervals of 2 seconds. The total tracked polarization trajectory length is ~ 425 Mrad on the Poincaré sphere.

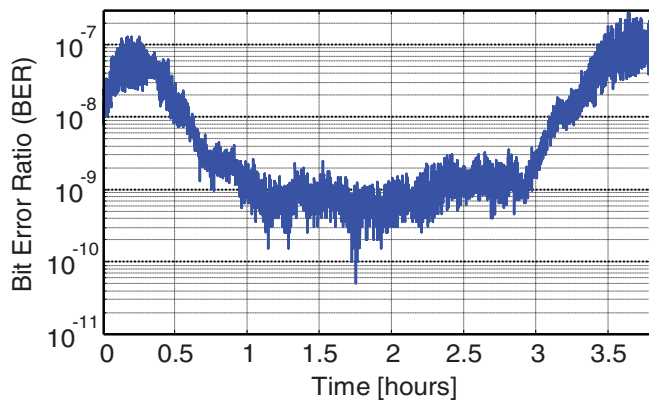

Fig. 6. BER during 3 h with reduced OSNR after transmission over 430 km with 40 krad/s scrambling speed.

V. CONCLUSION

We demonstrated fast automatic optical polarization demultiplex of PDM-RZ-DPSK signals. These were transmitted error-free over 430 km while being subjected to fast polarization changes. Transmitter laser frequency modulation in conjunction with a differential polarization channel delay allowed crosstalk detection, without pilot tones. Polarization scrambling at 40 krad/s speed causes OSNR penalties of only ~ 0.3 dB.

REFERENCES

- [1] R. Noé, H. Heidrich, and D. Hoffmann, "Endless polarization control systems for coherent optics," *J. Lightw. Technol.*, vol. 6, no. 7, pp. 1199–1207, Jul. 1988.
- [2] S. Hinz, D. Sandel, F. Wüst, and R. Noé, "Interference detection enables 2×20 Gbit/s RZ polarization division multiplex transmission," *Electron. Lett.*, vol. 37, no. 8, pp. 511–512, 2001.
- [3] R. Noé, S. Hinz, D. Sandel, and F. Wüst, "Crosstalk detection schemes for polarization division multiplex transmission," *J. Lightw. Technol.*, vol. 19, no. 10, pp. 1469–1475, Oct. 2001.
- [4] D. Sandel, F. Wüst, V. Mirvoda, and R. Noé, "Standard (NRZ 1×40 Gbit/s, 210 km) and polarization multiplex (CS-RZ, 2×40 Gbit/s, 212 km) transmissions with PMD compensation," *IEEE Photon. Technol. Lett.*, vol. 14, no. 8, pp. 1181–1183, Aug. 2002.
- [5] S. Bhandare, *et al.*, "5.94 Tbit/s, 1.49 bit/s/Hz ($40 \times 2 \times 2 \times 40$ Gbit/s) RZ-DQPSK polarization division multiplex C-band transmission over 324 km," *IEEE Photon. Technol. Lett.*, vol. 17, no. 4, pp. 914–916, Apr. 2005.
- [6] X. S. Yao, L.-S. Yan, B. Zhang, A. E. Willner, and J. Jiang, "All-optic scheme for automatic polarization division demultiplexing," *Opt. Express*, vol. 15, no. 12, pp. 7407–7414, 2007.
- [7] A. H. Gnauck, *et al.*, "25.6-Tb/s C+L-band transmission of polarization-multiplexed RZ-DQPSK signals," in *Proc. OFC*, Anaheim, CA, USA, Mar. 2007, pp. 1–3, paper PDP19.
- [8] H. Masuda, *et al.*, "20.4-Tb/s (204×111 Gb/s) transmission over 240 km using bandwidth-maximized hybrid Raman/EDFAs," in *Proc. OFC*, Anaheim, CA, USA, Mar. 2007, pp. 1–3, paper PDP20.
- [9] J.-X. Cai, *et al.*, "40 Gb/s transmission using polarization division multiplexing (PDM) RZ-DBPSK with automatic polarization tracking," in *Proc. OFC 2008*, pp. 1–3, paper PDP4.
- [10] T. Ito, S. Fujita, E. L. T. de Gabory, S. Shioiri, and K. Fukuchi, "Precise analysis of transmission impairments of Pol-Mux 110 Gb/s RZ-DQPSK with automatic Pol-Dmux using Straight 2,000-km SMF line," in *Proc. ECOC 2008*, Sep., pp. 1–2, paper We.1.E.6.
- [11] S. Yunfeng, *et al.*, "Design of polarization de-multiplexer and PMD compensator for 112 Gb/s direct-detect PDM RZ-DQPSK systems," *J. Lightw. Technol.*, vol. 28, no. 22, pp. 3282–3293, Nov. 15, 2010.
- [12] B. Koch, R. Noé, V. Mirvoda, D. Sandel, V. Filsinger, and K. Puntieri, "40-krad/s polarization tracking in 200-Gb/s PDM-RZ-DQPSK transmission over 430 km," *IEEE Photon. Technol. Lett.*, vol. 22, no. 9, pp. 613–615, May 1, 2010.
- [13] J. Zhang *et al.*, "Transmission of 112 Gb/s PM-RZ-DQPSK over 960 km with adaptive polarization tracking based on power difference," in *Proc. 36th ECOC 2010*, Sep., pp. 1–3, paper P2.09.
- [14] *Commercial Polarization Control up to 100 krad/s*. (2012 Jun. 25) [Online]. Available: http://www.novoptel.de/Control/Control_EPC1000_en.php